

Installation and Maintenance Instructions Freewheel Type AE

To avoid premature failure of the freewheel or possible machine malfunction, installation of the freewheel should be carried out by suitably qualified personnel and according to the following instructions.

STIEBER will not accept liability in cases of non-compliance with these instructions!

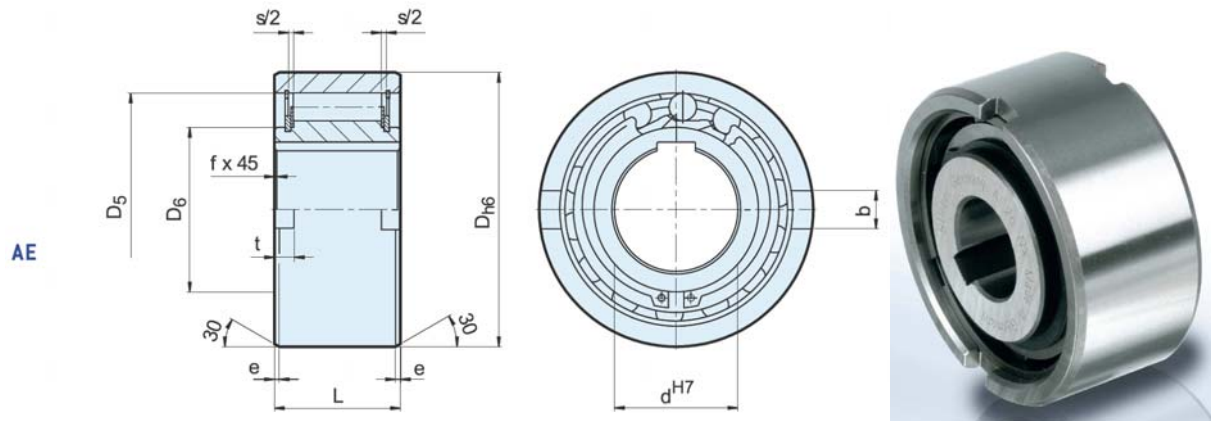

Type	Size	Overrunning speeds											Weight	Drag torque	
		d^{H7} [mm]	T_{KH}^{10} [Nm]	n_{max}^{20} [min ⁻¹]	n_{max}^{30} [min ⁻¹]	D_{H6} [mm]	D_5 [mm]	D_4 [mm]	L [mm]	s [mm]	f [mm]	e [mm]			b [mm]
AE	12	17	3100	6000	37	28	20	20	4,5	0,5	0,8	6	3	0,11	0,7
	15	55	2300	5400	47	37	26	30	4,5	0,8	1,2	7	3,5	0,30	3,5
	20	146	2000	3600	62	50	35	34	5,5	0,8	1,2	8	3,5	0,55	8,4
	25	285	1700	2600	80	68	45	37	6,5	1	1,8	9	4	0,98	14
	30	500	1500	2100	90	75	50	44	6,2	1	1,8	12	5	1,50	23
	35	720	1300	1950	100	80	55	48	3,8	1	1,8	13	6	2,00	60
	40	1030	1200	1700	110	90	60	56	3,8	1,5	1,8	15	7	2,80	72
	45	1125	1050	1600	120	95	65	56	3,8	1,5	2,6	16	7	3,30	140
	50	2150	950	1300	130	110	75	63	5,8	1,5	2,6	17	8	4,20	180
	55	2675	850	1200	140	115	82	67	3,8	2	2,6	18	9	5,20	190
	60	3500	800	1100	150	125	90	78	7,6	2	2,6	18	9	6,80	240
	70	5813	650	900	170	140	100	95	7,6	2,5	2,6	20	9	10,5	320

Prior to Installation:

The freewheels should be unpacked and installed in a clean dry working environment.

Remove the corrosion inhibitor using flushing oil.

The freewheeling direction should be checked prior to installation.

Reverse unit on shaft to change freewheeling direction.

The inner race should be fitted to a shaft of h6 or j6 tolerance.

The outer housing should be to K7 or R6 tolerance.

The concentricity and angular alignment of the shaft relative to the outer housing should be within the limits specified in the table below.

Permissible concentricity and alignment errors:

Bore Ø [mm]	Concentricity [mm]	Parallelism [mm]	Axial clearance S [mm]
12-15	0,02	0,03	4,5
20	0,035	0,03	5,5
25	0,035	0,03	6,5
30	0,035	0,03	6,2
35-45	0,06	0,03	3,8
50	0,06	0,03	5,8
55	0,06	0,03	3,8
60-70	0,1	0,045	7,6

We recommend ball bearings with normal bearing clearance are installed adjacent to the freewheel.

Installation:

Use a key to DIN 6885 sheet 1. The key should be the length of the freewheel hub.

The torque is transmitted at the outer race via a pressfit (R6/h6), or by the slots in the outer race. (The housing can be to H7 tolerance if the slots are used to transmit torque)

During installation, an evenly distributed axial load should be applied simultaneously to both the inner and outer races.

Avoid localised axial loading on either the inner or outer race.

After Installation:

After installation, ensure the unit rotates smoothly in the direction of freewheeling.

Prior to use, 1/3 to 1/2 of the free space within the unit should be filled with oil of the recommended grade.

Lubrication and Maintenance:

- The lubricating oil should be changed after approximately 10 hours operation. Further oil changes should be made after every 2000 hours. (In arduous applications change oil every 1000 operating hours).
- With ambient temperatures above 80°C, check lubrication regularly.
- For operating temperatures below -20°C and above 100°C contact the technical department of your lubricant suppliers.
- For indexing applications, oil types with a kinematic viscosity of about 10mm²/sat the normal operating temperature are recommended.
- If grease lubrication is to be used please consult your Stieber stockist. Excessive grease may lead to malfunction of the freewheel. Only 30 to 40% of the free space between the races should be grease filled.

Lubricants with slip additives such as graphite, Molykote or similar agents should be avoided

Recommended Lubricants

	Ambient temperature				Grease
	-40°C to -15°C	-15°C to +15°C	+15°C to +30°C	+30°C to +50°C	
	Operating temperature				
	-20°C to +20°C	+10°C to +50°C	+40°C to +70°C	+50°C to +85°C	
	Oil				
ISO - VG DIN 51519	10	22	46	100	
ARAL	SUMOROL CM10	SUMOROL CM22	MOTANOL HK46	DEGOL CL100T	ARALUB HL2
BP	ENERGOL CS10	ENERGOL CS22	ENERGOL CS46	ENERGOL RC100	ENERGREASE LS2
DEA	ASTRON HL10	ASTRON HL22	ASTRON HL46	ASTRON HL100	GLISSANDO 20
ESSO	NUTO H10 SPINESSO 10	NUTO H22 SPINESSO 22	NUTO H46 TERESSO 46	NUTO H100	BEACON 2
FUCHS	RENOLIN MR3	RENOLIN DTA22	RENOLIN DTA46	RENOLIN MR30	RENOLIT LZR2
KLÜBER	CRUCOLAN 10	CRUCOLAN 22	CRUCOLAN 46	CRUCOLAN 100	POLYLUB WH2
MOBIL	VELOCITE No6	VELOCITE No10	VACTRA MEDIUM VG46	VACTRA HEAVY VG100	MOBILUX 2
SHELL	MORLINA 10	MORLINA 22	MORLINA 46	MORLINA 100	ALVANIA G2
TOTAL	AZZOLA ZS10	AZZOLA ZS22	AZZOLA ZS46	AZZOLA ZS100	MULTIS 2
Alternatively we strongly recommend the use of multigrade oils SAE 10W-40 at working temperature between 0° and +80 ° C.					

The ambient temperature is to be taken as a guide line. The operating temperature is determinant for the choice of the viscosity.

Corrosion inhibitor: Rivolta KSP

Time of protection: 6 to 12 months

Recommendation: Prior to use, remove corrosion inhibitor using flushing oil.

The maximum overrunning speeds given in our literature apply to oil lubricated units. For grease lubrication the quoted speeds must be halved. Please refer to the 'Lubrication & Maintenance' section in our main catalogue.