

旋削形ニードルベアリング 分離形 (内輪なし) RNAF(W)タイプ

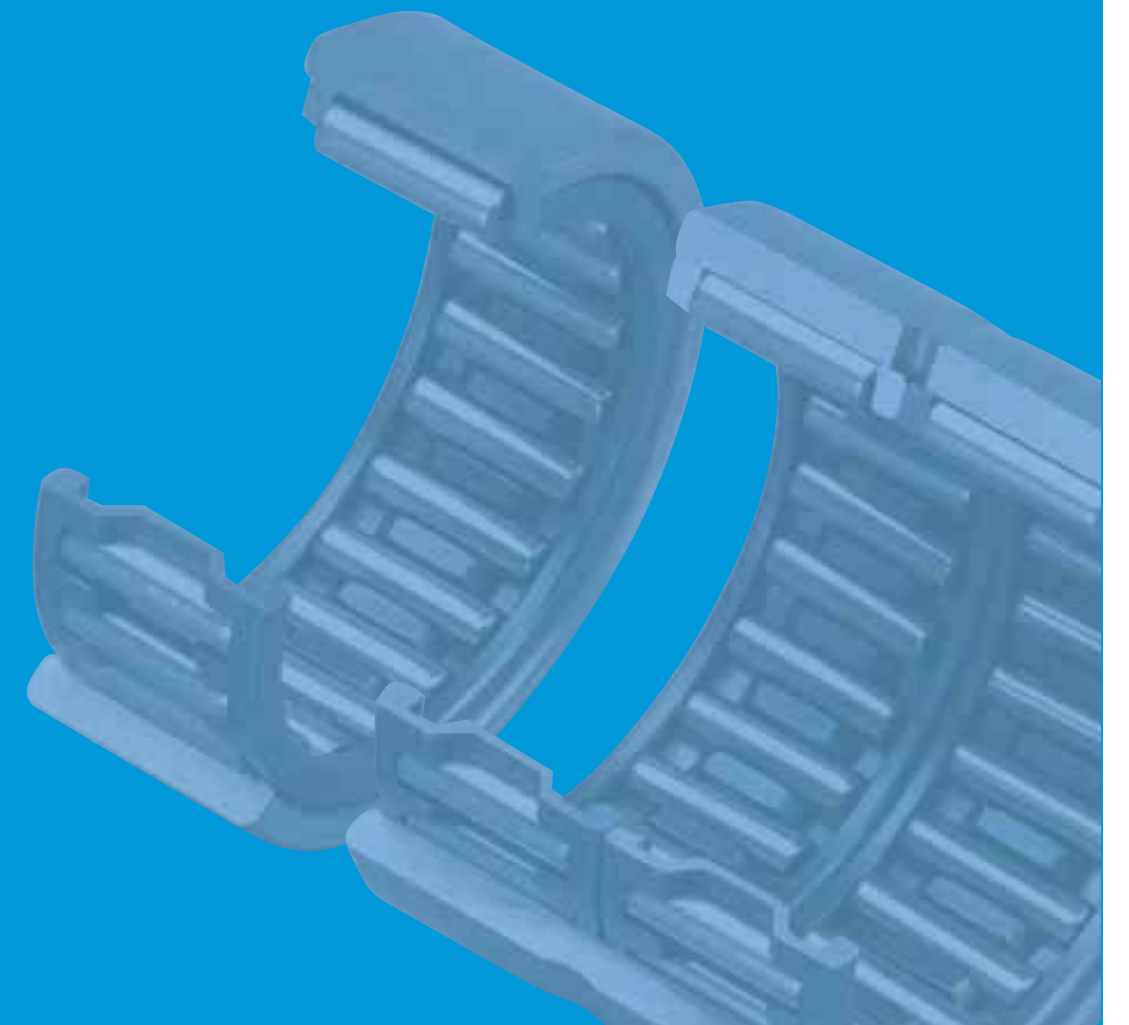

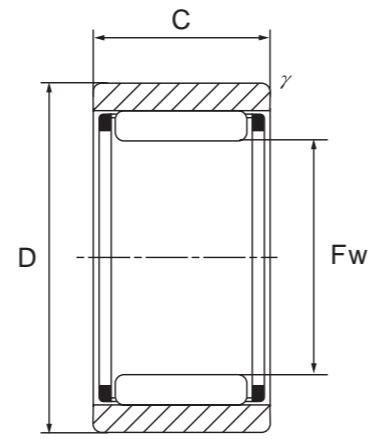

旋削形ニードルベアリング 分離型 (内輪なし)



RNAF

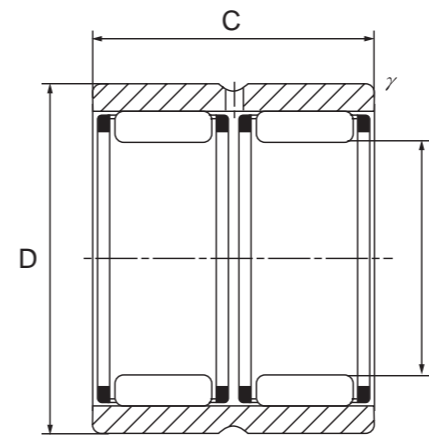

RNAFW

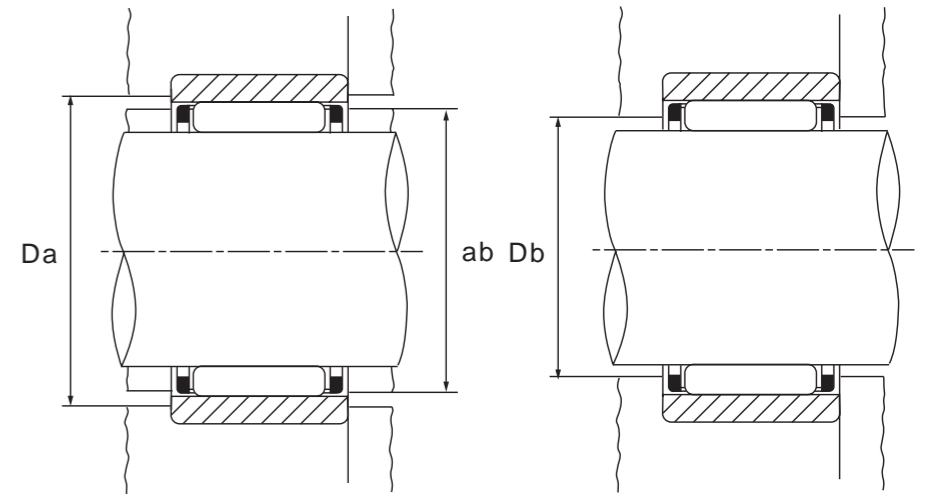

JNS RNAF(W)タイプ

| Fw | 主要寸法 (mm) | | | 注1) γs min | 取付関係寸法 (mm) | | | 基本動 定格荷重 Cr N | 基本静 定格荷重 Cor N | 許容 回転数 注2) rpm | 呼び型番 RNAF(W) | 質量 (参考) g |
|----|-----------|----|--------|---------------|-------------|------|--------|------------------------|-------------------------|-------------------------|-----------------|-----------------|
| | D | C | db | | Da 最大 | Db | | | | | | |
| 5 | 10 | 8 | 6.7 | 0.2 | 8.4 | 5.4 | 2 500 | 2 000 | 40 000 | RNAF 5108 | 3 | |
| 6 | 13 | 8 | 8.4 | 0.3 | 11 | 6.4 | 2 500 | 2 100 | 37 000 | RNAF 6138 | 5.5 | |
| 7 | 14 | 8 | 9.4 | 0.3 | 12 | 7.4 | 2 900 | 2 600 | 34 000 | RNAF 7148 | 6 | |
| 8 | 15 | 10 | 10.4 γ | 0.3 | 13 | 8.4 | 3 600 | 3 600 | 32 000 | RNAF 81510 | 8 | |
| | 16 | 20 | 10.8 | 0.3 | 14 | 8.4 | 6 200 | 7 200 | 32 000 | RNAFW 81620 | 20 | |
| 10 | 17 | 10 | 12.4 | 0.3 | 15 | 10.4 | 4 100 | 4 500 | 28 000 | RNAF 101710 | 10 | |
| | 20 | 12 | 13.5 | 0.3 | 18 | 10.4 | 6 000 | 6 000 | 28 000 | RNAF 102012 | 19 | |
| 12 | 22 | 12 | 17.5 | 0.3 | 20 | 12.4 | 9 000 | 8 400 | 26 000 | RNAF 122212 | 19 | |
| 14 | 22 | 13 | 17.6 | 0.3 | 20 | 14.6 | 7 800 | 9 400 | 24 000 | RNAF 142213 | 18 | |
| | 22 | 20 | 17.6 | 0.3 | 20 | 14.6 | 10 800 | 14 200 | 24 000 | RNAFW 142220 | 28 | |
| | 26 | 12 | 19.4 | 0.3 | 24 | 14.6 | 9 800 | 9 700 | 24 000 | RNAF 142612 | 29 | |
| 15 | 23 | 13 | 18.6 | 0.3 | 21 | 15.6 | 8 200 | 10 200 | 23 000 | RNAF 152313 | 20 | |
| | 23 | 20 | 18.6 | 0.3 | 21 | 15.6 | 11 400 | 15 400 | 23 000 | RNAFW 152320 | 31 | |
| 16 | 24 | 13 | 19.6 | 0.3 | 22 | 16.6 | 8 600 | 11 000 | 23 000 | RNAF 162413 | 21 | |
| | 24 | 20 | 19.6 | 0.3 | 22 | 16.6 | 11 900 | 16 700 | 23 000 | RNAFW 162420 | 32 | |
| | 28 | 12 | 21.4 | 0.3 | 26 | 16.6 | 10 500 | 10 900 | 23 000 | RNAF 162812 | 32 | |
| 17 | 25 | 13 | 20.6 | 0.3 | 23 | 17.6 | 9 000 | 11 900 | 22 000 | RNAF 172513 | 22 | |
| | 25 | 20 | 20.6 | 0.3 | 23 | 17.6 | 12 400 | 17 900 | 22 000 | RNAFW 172520 | 33 | |

注1) 面取寸法γの最小許容寸法です。
注2) 許容回転数は油潤滑に適用。グリース潤滑では上記の60%の値になります。



旋削形ニードルベアリング 分離型 (内輪なし)

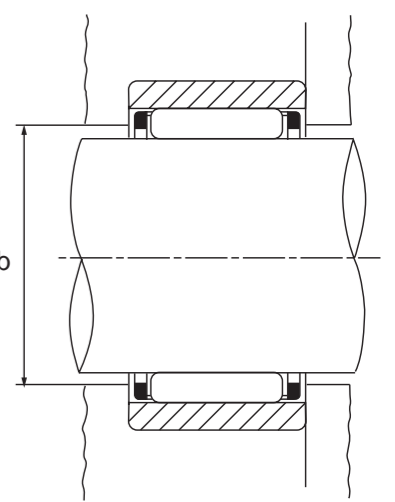
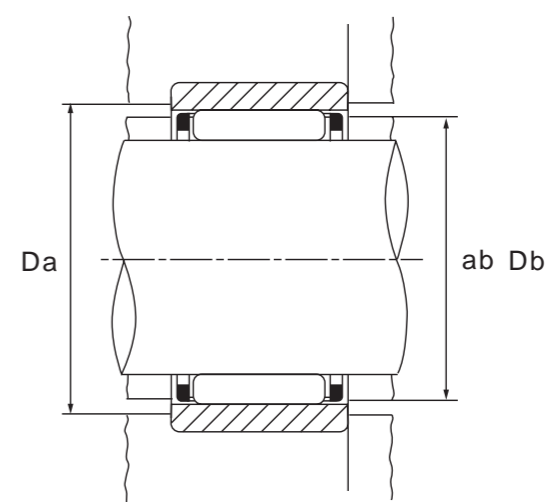
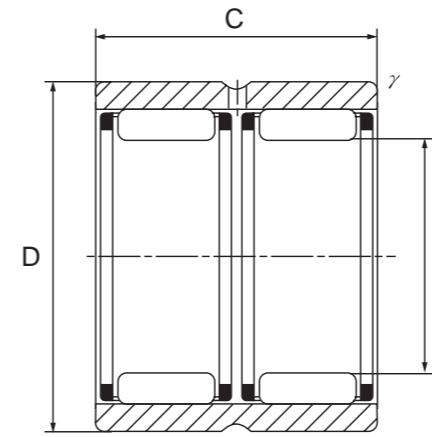
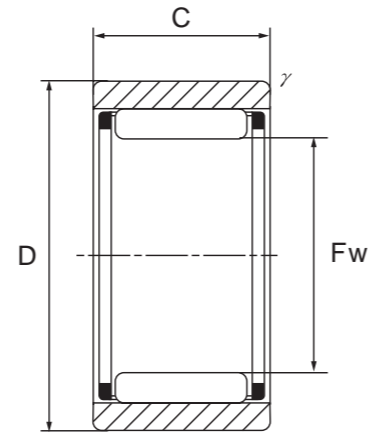

JNS RNAF(W)タイプ

| Fw | 主要寸法 (mm) | | | 注1) γ's min | 取付関係寸法 (mm) | | | 基本動 定格荷重 Cr N | 基本静 定格荷重 Cor N | 許容 回転数 注2) rpm | 呼び型番 RNAF(W) | 質量 (参考) g |
|----|-----------|----|------|----------------|-------------|------|--------|------------------------|-------------------------|--|-----------------|-----------------|
| | D | C | db | | Da 最大 | Db | | | | | | |
| 18 | 26 | 13 | 21.6 | 0.3 | 24 | 18.6 | 9 300 | 12 700 | 21 000 | RNAF 182613 RNAFW 182620 RNAF 183012 RNAFW 183024 | 23 | |
| | 26 | 20 | 21.6 | 0.3 | 24 | 18.6 | 12 800 | 19 100 | 21 000 | | 35 | |
| | 30 | 12 | 23.4 | 0.3 | 28 | 18.6 | 11 800 | 13 000 | 21 000 | | 35 | |
| | 30 | 24 | 23.4 | 0.3 | 28 | 18.6 | 20 200 | 26 200 | 21 000 | | 70 | |
| 20 | 28 | 13 | 23.6 | 0.3 | 26 | 20.6 | 9 600 | 13 500 | 20 000 | RNAF 202813 RNAFW 202826 RNAF 203212 RNAFW 203224 | 25 | |
| | 28 | 26 | 23.6 | 0.3 | 26 | 20.6 | 16 500 | 27 100 | 20 000 | | 50 | |
| | 32 | 12 | 25.4 | 0.3 | 30 | 20.6 | 12 400 | 14 300 | 20 000 | | 37 | |
| | 32 | 24 | 25.4 | 0.3 | 30 | 20.6 | 21 200 | 28 600 | 20 000 | | 75 | |
| 22 | 30 | 13 | 25.6 | 0.3 | 28 | 22.6 | 10 200 | 15 200 | 18 000 | RNAF 223013 RNAFW 223026 RNAF 223516 RNAFW 223532 | 27 | |
| | 30 | 26 | 25.6 | 0.3 | 28 | 22.6 | 17 600 | 30 300 | 18 000 | | 54 | |
| | 35 | 16 | 27.8 | 0.3 | 33 | 22.6 | 17 600 | 20 900 | 18 000 | | 59 | |
| | 35 | 32 | 27.8 | 0.3 | 33 | 22.6 | 30 200 | 41 900 | 18 000 | | 117 | |
| 25 | 35 | 17 | 29.5 | 0.3 | 33 | 25.6 | 17 300 | 26 600 | 16 000 | RNAF 253517 RNAFW 253526 RNAF 253716 RNAFW 253732 | 51 | |
| | 35 | 26 | 29.5 | 0.3 | 33 | 25.6 | 22 500 | 37 200 | 16 000 | | 78 | |
| | 37 | 16 | 30.4 | 0.3 | 35 | 25.6 | 19 400 | 24 500 | 16 000 | | 57 | |
| | 37 | 32 | 30.4 | 0.3 | 35 | 25.6 | 33 200 | 49 000 | 16 000 | | 114 | |
| 28 | 40 | 16 | 33.4 | 0.3 | 38 | 28.6 | 20 100 | 26 500 | 14 000 | RNAF 284016 RNAFW 284032 | 63 | |
| | 40 | 32 | 33.4 | 0.3 | 38 | 28.6 | 34 400 | 53 000 | 14 000 | | 125 | |

注1) 面取寸法γの最小許容寸法です。
注2) 許容回転数は油潤滑に適用。グリース潤滑では上記の60%の値になります。



旋削形ニードルベアリング 分離型 (内輪なし)

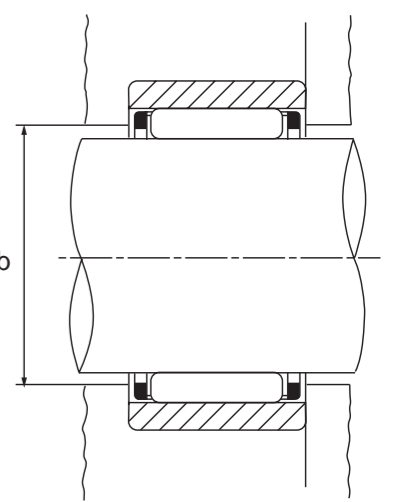
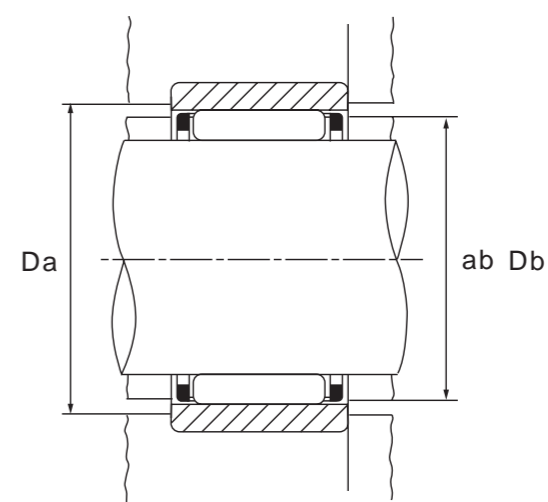
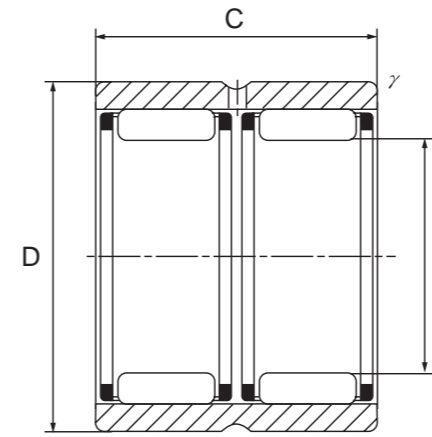
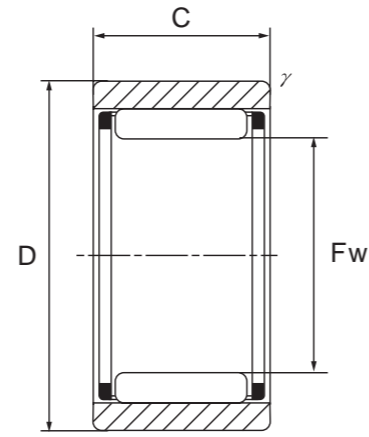

JNS RNAF(W)タイプ

| Fw | 主要寸法 (mm) | | | 注1) γs min | 取付関係寸法 (mm) | | | 基本動 定格荷重 Cr N | 基本静 定格荷重 Cor N | 許容 回転数 注2) rpm | 呼び型番 RNAF(W) | 質量 (参考) g |
|----|-----------|----|-----|---------------|-------------|------|--------|------------------------|-------------------------|-------------------------|-----------------|-----------------|
| | D | C | db | | Da 最大 | Db | | | | | | |
| 30 | 40 | 17 | 0.3 | 34.5 | 38 | 30.6 | 18 600 | 31 100 | 13 000 | RNAF 304017 | 59 | |
| | 40 | 26 | 0.3 | 34.5 | 38 | 30.6 | 24 200 | 43 400 | 13 000 | RNAFW 304026 | 91 | |
| | 42 | 16 | 0.3 | 35.4 | 40 | 30.6 | 20 800 | 28 300 | 13 000 | RNAF 304216 | 66 | |
| | 42 | 32 | 0.3 | 35.4 | 40 | 30.6 | 35 700 | 56 800 | 13 000 | RNAFW 304232 | 132 | |
| 35 | 45 | 17 | 0.3 | 39.5 | 43 | 35.6 | 20 500 | 36 900 | 11 000 | RNAF 354517 | 68 | |
| | 45 | 26 | 0.3 | 39.5 | 43 | 35.6 | 26 600 | 51 600 | 11 000 | RNAFW 354526 | 103 | |
| | 47 | 16 | 0.3 | 40.4 | 45 | 35.6 | 23 000 | 33 800 | 11 000 | RNAF 354716 | 76 | |
| | 47 | 32 | 0.3 | 40.4 | 45 | 35.6 | 39 500 | 67 800 | 11 000 | RNAFW 354732 | 151 | |
| 40 | 50 | 17 | 0.3 | 43.5 | 48 | 40.8 | 22 200 | 42 700 | 10 000 | RNAF 405017 | 75 | |
| | 50 | 34 | 0.3 | 43.5 | 48 | 40.8 | 38 000 | 85 300 | 10 000 | RNAFW 405034 | 152 | |
| | 55 | 20 | 0.3 | 45.2 | 53 | 40.8 | 31 500 | 48 000 | 10 000 | RNAF 405520 | 142 | |
| | 55 | 40 | 0.3 | 45.2 | 53 | 40.8 | 53 900 | 96 000 | 10 000 | RNAFW 405540 | 280 | |
| 45 | 55 | 17 | 0.3 | 48.5 | 53 | 45.8 | 23 200 | 47 200 | 10 000 | RNAF 455517 | 84 | |
| | 55 | 34 | 0.3 | 48.5 | 53 | 45.8 | 39 900 | 94 200 | 10 000 | RNAFW 455534 | 167 | |
| | 62 | 20 | 0.3 | 50.9 | 60 | 45.8 | 33 200 | 53 300 | 9 000 | RNAF 456220 | 185 | |
| | 62 | 40 | 0.3 | 50.9 | 60 | 45.8 | 57 000 | 106 900 | 9 000 | RNAFW 456240 | 370 | |
| 50 | 62 | 20 | 0.3 | 54.2 | 60 | 50.8 | 27 100 | 59 300 | 8 000 | RNAF 506220 | 139 | |
| | 62 | 40 | 0.3 | 54.2 | 60 | 50.8 | 46 400 | 118 700 | 8 000 | RNAFW 506240 | 276 | |
| | 65 | 20 | 0.3 | 55.2 | 63 | 50.8 | 35 900 | 61 100 | 8 000 | RNAF 506520 | 170 | |
| | 65 | 40 | 0.6 | 55.2 | 61 | 50.8 | 61 500 | 122 600 | 8 000 | RNAFW 506540 | 345 | |

注1) 面取寸法γの最小許容寸法です。
注2) 許容回転数は油潤滑に適用。グリース潤滑では上記の60%の値になります。



旋削形ニードルベアリング 分離型 (内輪なし)

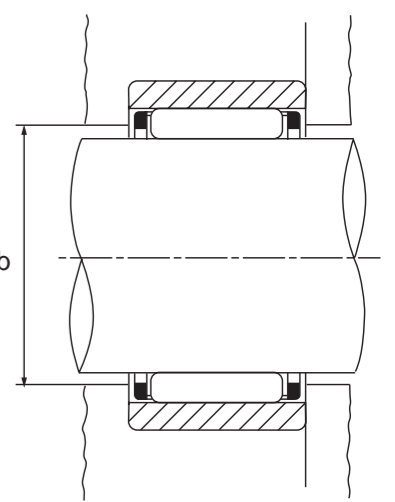
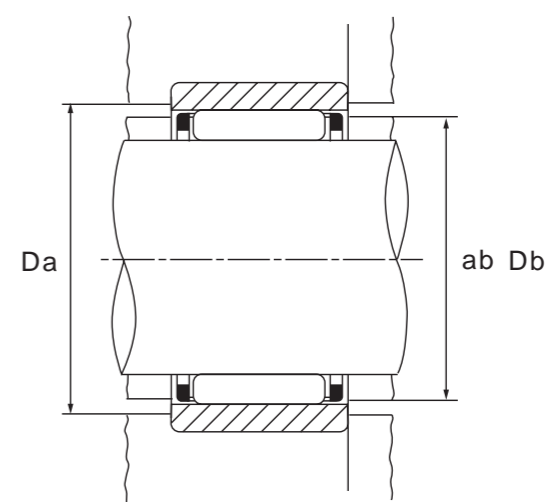
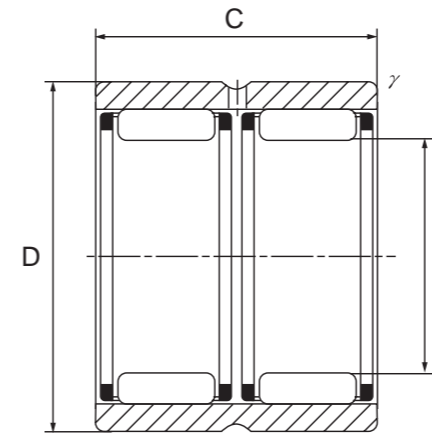
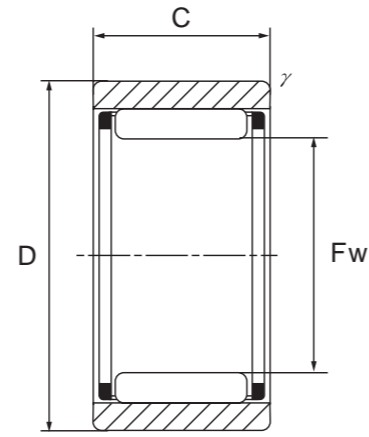

JNS RNAF(W)タイプ

| Fw | 主要寸法 (mm) | | | db | 取付関係寸法 (mm) | | 基本動 定格荷重 Cr N | 基本静 定格荷重 Cor N | 許容 回転数 注2) rpm | 呼び型番 RNAF(W) | 質量 (参考) g |
|-----|-----------|----|---------------|------|-------------|------|------------------------|-------------------------|-------------------------|-----------------|-----------------|
| | D | C | 注1) γs min | | Da 最大 | Db | | | | | |
| 55 | 68 | 20 | 0.6 | 59.5 | 64 | 55.8 | 28 500 | 66 000 | 7 500 | RNAF 556820 | 167 |
| | 68 | 40 | 0.6 | 59.5 | 64 | 55.8 | 48 900 | 132 400 | 7 500 | RNAFW 556840 | 330 |
| | 72 | 20 | 0.6 | 60.9 | 68 | 55.8 | 37 400 | 66 400 | 7 500 | RNAF 557220 | 215 |
| | 72 | 40 | 0.6 | 60.9 | 68 | 55.8 | 64 100 | 132 400 | 7 500 | RNAFW 557240 | 435 |
| 60 | 78 | 20 | 1 | 66.3 | 73 | 60.8 | 38 900 | 71 700 | 6 500 | RNAF 607820 | 255 |
| | 78 | 40 | 1 | 66.3 | 73 | 60.8 | 66 700 | 143 200 | 6 500 | RNAFW 607840 | 510 |
| 65 | 85 | 30 | 1 | 72 | 80 | 66 | 59 300 | 127 500 | 6 000 | RNAF 658530 | 465 |
| | 85 | 60 | 1 | 72 | 80 | 66 | 102 000 | 254 000 | 6 000 | RNAFW 658560 | 950 |
| 70 | 90 | 30 | 1 | 77 | 85 | 71 | 61 200 | 135 300 | 5 500 | RNAF 709030 | 500 |
| | 90 | 60 | 1 | 77 | 85 | 71 | 104 900 | 271 600 | 5 500 | RNAFW 709060 | 1 000 |
| 75 | 95 | 30 | 1 | 82 | 90 | 76 | 63 200 | 144 200 | 5 500 | RNAF 759530 | 530 |
| | 95 | 60 | 1 | 82 | 90 | 76 | 108 900 | 289 300 | 5 500 | RNAFW 759560 | 1 050 |
| 80 | 100 | 30 | 1 | 87 | 95 | 81 | 64 900 | 153 000 | 5 000 | RNAF 8010030 | 560 |
| | 100 | 60 | 1 | 87 | 95 | 81 | 111 800 | 306 000 | 5 000 | RNAFW 8010060 | 1 120 |
| 85 | 105 | 30 | 1 | 92 | 100 | 86 | 66 600 | 160 800 | 4 800 | RNAF 8510530 | 590 |
| 90 | 110 | 30 | 1 | 97 | 105 | 91 | 69 500 | 173 600 | 4 500 | RNAF 9011030 | 620 |
| 95 | 115 | 30 | 1 | 102 | 110 | 96 | 70 900 | 182 400 | 4 200 | RNAF 9511530 | 650 |
| 100 | 120 | 30 | 1 | 107 | 115 | 101 | 72 600 | 191 200 | 4 000 | RNAF 10012030 | 690 |

注1) 面取寸法γの最小許容寸法です。
注2) 許容回転数は油潤滑に適用。グリース潤滑では上記の60%の値になります。