

RIZ..ELG2

Back of
RIZ..ELG2

TYPE



Type RIZ..ELG2 is a centrifugal lift off sprag type freewheel when the inner race is overrunning. Only this race is designed for freewheeling. It is a self-contained unit designed for overrunning clutch applications.

Typically used in crawl drives where the overrunning speed is high, but the drive speed is low and does not exceed the maximum driving speed specified in the table. It is a type RIZ (» see page 84 for further information) equipped with an EL elastic coupling and a cover G2.

The EL type is a high performance coupling used to damp torsional vibrations and to accept misalignment without excess bearing load.

The inner race must overrun and will be connected to the driven machine shaft. When ordered complete, the unit is delivered grease lubricated, ready for either horizontal or vertical installation. The torques given in the table are determined by the freewheel capacity.

RIZ..ELG2

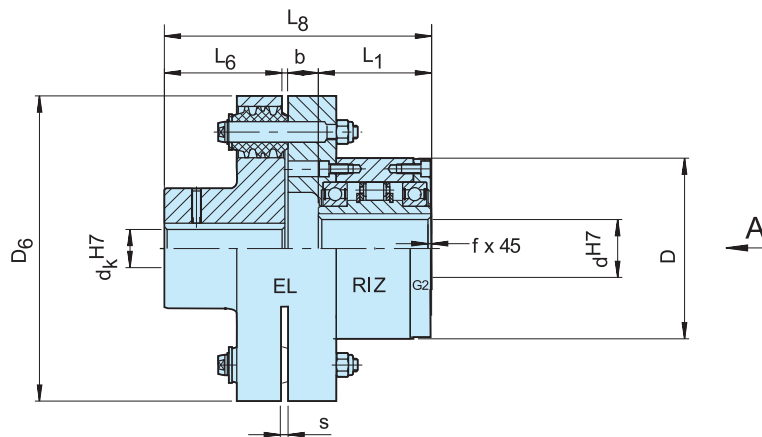

Type	Size	EL	T_{KN} (Nm)	Speeds			d_K^{H7} (mm)	D (mm)	L_1 (mm)	D_6 (mm)	L_6 (mm)	L_8 (mm)	b (mm)	s (mm)	f (mm)	Weight (kg)
				$n_{max}^{1)}$ (min ⁻¹)	$n_{min}^{2)}$ (min ⁻¹)	$n_{max}^{3)}$ (min ⁻¹)										
RIZ..ELG2	30	5	375	290	700	9000	20...55	100	68	160	60	147.5	19.5	2	1	11
	35	6	550	280	670	8500	25...75	110	74	190	75	166.5	17.5	2	1	17
	40	6	800	260	630	7500	25...75	125	86	190	75	176.5	15.5	2	1.5	19
	45	6	912	255	610	6700	25...75	130	86	190	75	176.5	15.5	2	1.5	19
	50	7	1400	235	560	6000	30...85	150	94	225	90	208.5	24.5	2.5	1.5	31
	60	8	2350	210	510	5300	35...100	170	114	270	100	244	30	3	2	49
	70	10	3050	195	470	4000	45...120	190	134	340	140	312.5	38.5	3	2.5	90
	80	11	5800	155	375	4000	55...145	210	144	380	160	340	36	3	2.5	107
	90	12	8700	145	350	3000	65...165	230	158	440	180	388	50	3.5	3	170
	100	14	16000	140	340	2400	75...170	270	182	500	200	422.5	40.5	3.5	3	230
	130	16	23000	130	320	2400	85...180	310	212	560	220	482	50	4	3	330

NOTES

- 1) Inner race overruns
This maximum allowable torque transmission speed n_{max} must not be exceeded when transmitting torque
- 2) This minimum allowable overrunning speed n_{min} should not be reduced under continuous operation.
Possible reduction of this minimum speed on request
- 3) Inner race overruns
Keyway to DIN 6885.1

When ordering, please specify d_K bore diameter and direction of rotation seen from arrow „A“: „R“ Inner race overruns in clockwise direction, „L“ Inner race overruns in counterclockwise direction

» Refer to mounting and maintenance instructions page 16 to 19

MOUNTING EXAMPLE

